

Drawing No	
Title	Typical plant support frame configurations
Project	
Date	18-02-11
Drawn by	RHM

REV	DATE	BY	DESC



2 unit plant support frame

Designed to carry two standard AC units

- Components:
2x TP-1250 main supports
2x TP-1200 cross supports
4x TP-leg support leg complete



4 unit plant support frame

Designed to carry four standard AC units

- Components:
4x TP-1250 main supports
4x TP-1200 cross supports
6x TP-leg support leg complete



6 unit plant support frame

Designed to carry six standard AC units

- Components:
6x TP-1250 main supports
6x TP-1200 cross supports
8x TP-leg support leg complete

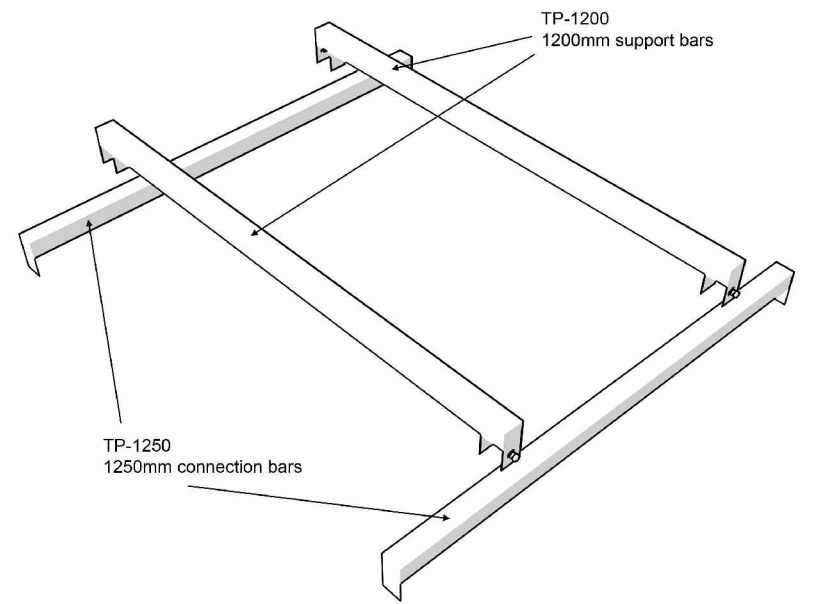
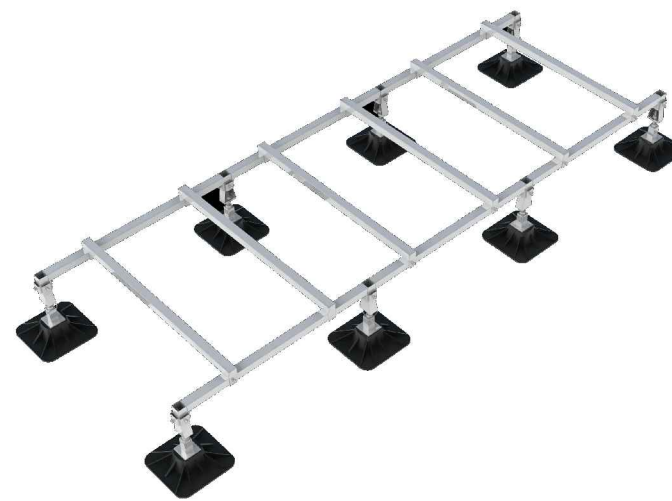

Fully adjustable support leg

Each frame utilises our unique fully adjustable support leg allowing the frame to be set at varying heights. The leg is connected to our recycled PVC support foot.



Supports frames can be connected along their width and length to form custom solutions.